

RV-2 SP / 5A SP



VERTICAL MACHINING CENTER

REALMECA

A machine dedicated to micromechanics

- ✓ Polymer composite machine base offering :
 - ✓ Excellent vibration dampening ;
 - ✓ Structural rigidity ;
 - ✓ Thermal stability ;
- ✓ High-speed spindle
- ✓ Designed for easy chip removal
- ✓ High precision linear bearing guideways
- ✓ Flatness, parallelism and perpendicularity within 2µm
- ✓ Column supports and cross slides directly integrated in the machine base
- ✓ Short kinematic chain of transmission
- ✓ Phosphate treatment of the metallic surfaces

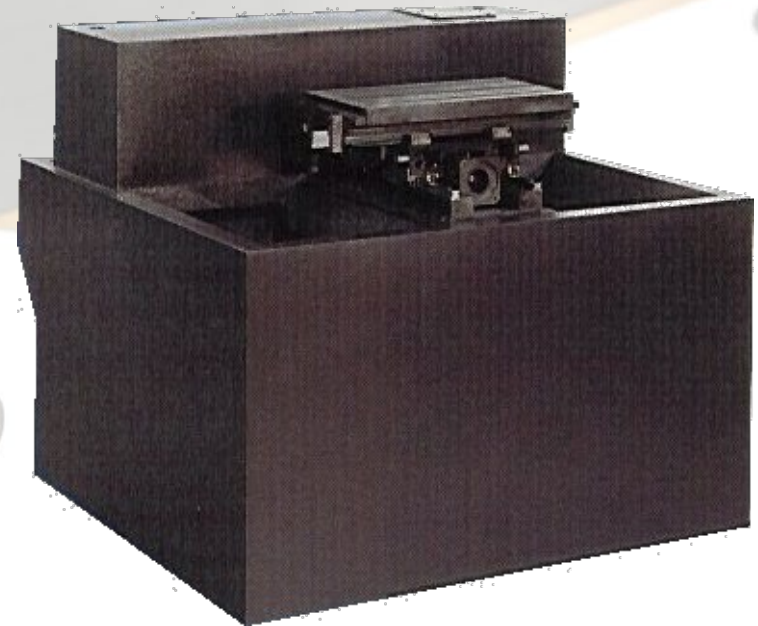

CAPACITY	
X axis	250 mm
Y axis	250 mm
Z axis	250 mm
SPINDLE	
HF80	
Max. speed	46 000 / 50 000 rpm
Max. rating	2,5 kW / 3,2 kW
Taper	HSK-E25
HT80 (option)	
Max. speed	30 000 rpm
Max. rating	3,3 kW / 4,3 kW
Taper	HSK-E25
FEEDRATES	
Max. cutting	30 m/min
Rapids	30 m/min
Precision	0,1μ
TOOL CHANGER	
Capacity	18 / 30 / 60 tools
SIZE / MASS	
Length / Width / Height	2300 x 1600 x 2000 mm
Weight	2750 kg

OPTIONS	
4th axis rotary	
A axis	360 000*0.001°
RV-2 version 5A	
B axis	100° / -10°
C axis	360°
Precision	0,1μ / 0,001°

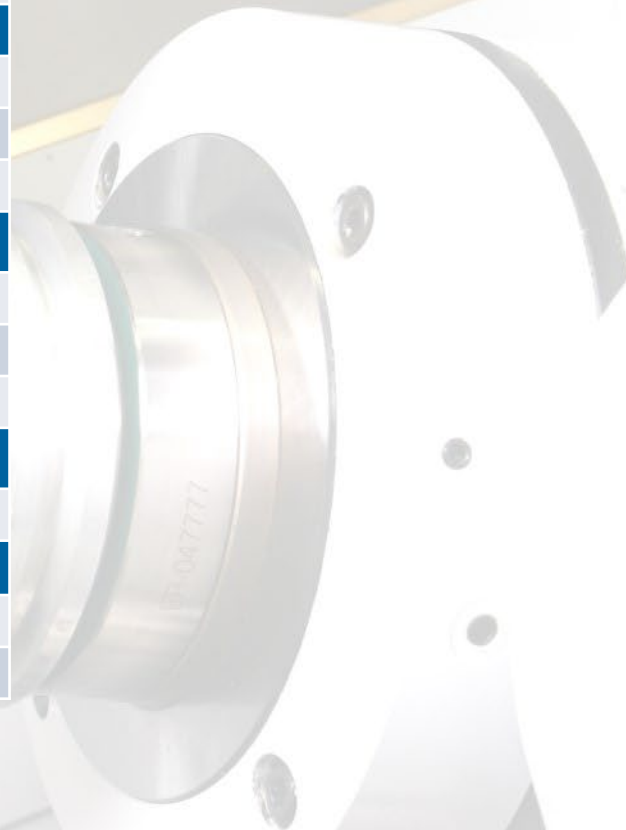

Tool probing (option)

Marposs : Mida laser 75 pico or Touch T18

Blum : Laser NT-H3D

Laser probing

Marposs : OP32

Renishaw : OMP40

Coolant flow

- Through surrounding nozzles
- Through the spindle (option)

Installation

Electrical : 30 kVA

Air : 6 bars mini

Tool probing

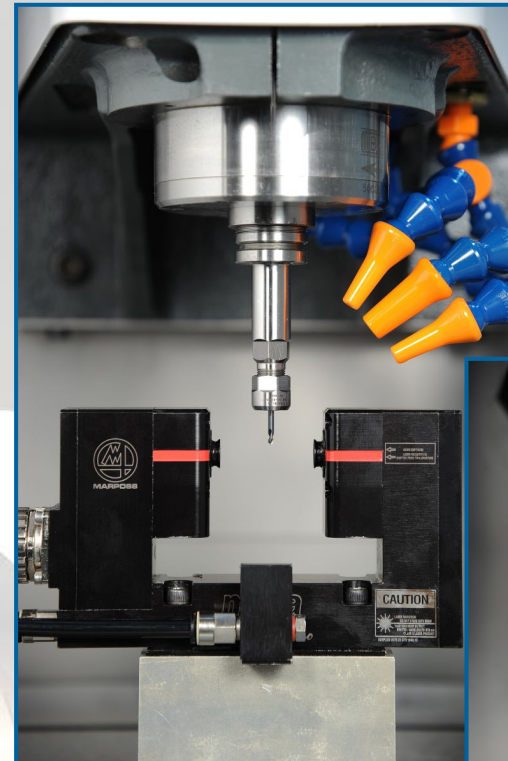

Laser probing



HF80

- Max. speed : **50.000 rpm**
- Max. rating : **2,5 kW**
- Torque : **0.6 Nm**
- Taper : **HSK E 25**
- Water cooling
- Air/Oil bearing lubrication
- Position encoder
- (Option) High pressure through spindle coolant : **80 bars Max. 42.000 rpm max**

RATING

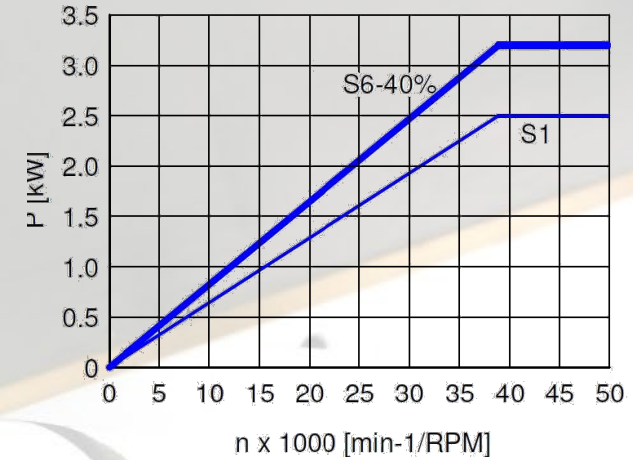

TORQUE

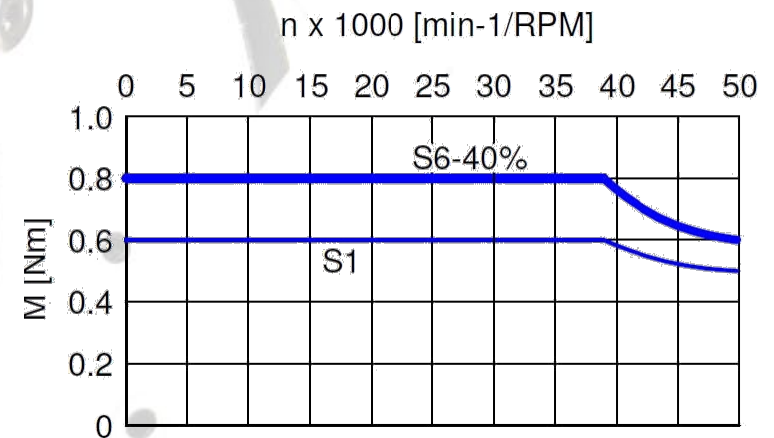

HT80 (option)

- Max. speed : **30.000 rpm**
- Max. rating : **3.3 kW**
- Torque : **4.2 Nm**
- Taper : **HSK E 25**
- Water cooling
- Air/Oil bearing lubrication
- Position encoder
- (Option) High pressure through spindle coolant : **80 bars Max. 42.000 rpm max**

RATING

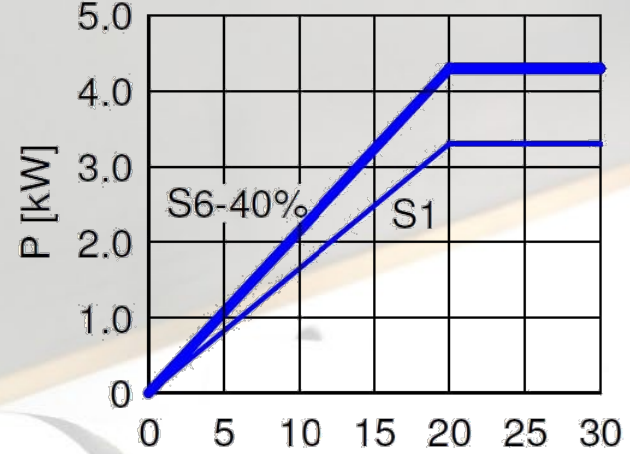

TORQUE

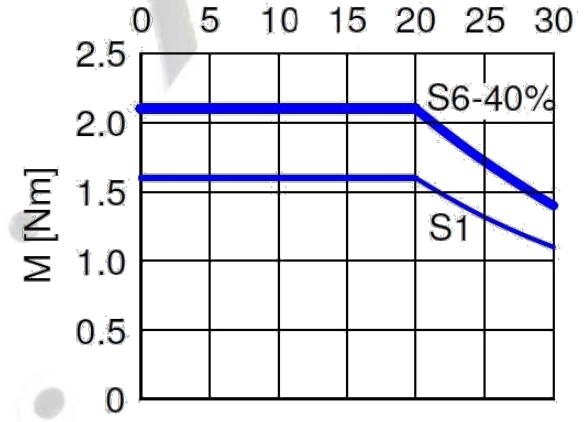

SIEMENS 840 SL

The Siemens 840 SL control panel displays several software windows:

- PROGRAMM**: Shows a 3D model of a cylindrical part.
- PROGRAMM**: Shows a 3D model of a square plate with a circular hole.
- Parameter editor**: Shows parameters for a drilling operation:
 - T: BOHRERS_6 D1
 - F: 0.800 mm/min
 - S: 1800 U/min
 - Schneft: 32.888 Link
 - D: 15.888
 - DF: 0.000
 - D1: 0.000 s
- Position display**: Shows coordinates:
 - X: 45.917
 - Y: 18.500
 - Z: 28.367
- Program list**:

Nr.	Programm	Werkzeug	Werkzeug-Nr.	Werkzeug-Ø	Werkzeug-L	Werkzeug-Ø	Werkzeug-L
1	SHRPHILL_Teil_27_5						
2	Planfräsen	✓	T-PLANFRÄSER FB_4/2	S380h	X8-180		
3	U-PROFIL						
4	Bahnfräsen	✓	T-FRÄSERZ25 FB_2/Z	S380h	Z8-0	Z1=40Link	
5	Bahnfräsen	✓	T-FRÄSERZ25 FB_2/Z	S380h	Z8-0	Z1=40Link	
6	Bahnfräsen	✓	T-FRÄSERZ25 FB_2/Z	S380h	Z8-0	Z1=40Link	
7	Kreisfräse	✓	T-FRÄSERZ25 FB_2/Z	S280h	X8-0	Y8-0	Z8-0

HEIDENHAIN 640

The Heidenhain 640 control panel displays several software windows:

- Execution PGM en continu**: Shows a list of operations:
 - BESSH PGM 12011 FR
 - BLK FOR1 0.1 Z X=00 Y=70 Z=20
 - BLK FOR1 0.2 X=150 Y=50 Z=40
 - TOOL CALL 17 2 S5500
 - L X=50 Y=30 Z=20 R0 F1000 H3
 - L X=30 Y=40 Z=10 RR
 - RND P20
 - L X=70 Y=60 Z=10
 - CT X=70 Y=30
- Hémorisation/édition programme**: Shows a dialog box for program modification:

Sens? en aval.=+1, en oppos.= -1

Value: -11.99

Value: +0.00
- Test de programme**: Shows a list of operations:
 - BESSH PGM 12000 FR
 - BLK FOR1 0.1 Z X=20 Y=32 Z=53
 - BLK FOR1 0.2 D=40 D=54 I2=53
 - TOOL CALL 01 2 S1000
 - L X=0 Y=0 R0 F3000
 - L 2+1 R0 F3000 P3
 - CYL DEF 5.0 POISE CIRCULAIRE
 - CYL DEF 5.1 DIST.1
 - CYL DEF 5.2 PROF. -3.6
 - CYL DEF 5.3 PRASSE F4000
 - CYL DEF 5.4 RAYONIS.05
 - CYL DEF 5.5 F5000 CR-
 - CYL CALL
 - CYL DEF 5.0 POISE CIRCULAIRE
 - CYL DEF 5.1 DIST.1

Micro-lubrication



Air-oil spindle lubrication



Oil filtration



Fire protection (option)



Electrostatic filtration



Filtration system (option)

PALLETISATION SYSTEM (option)

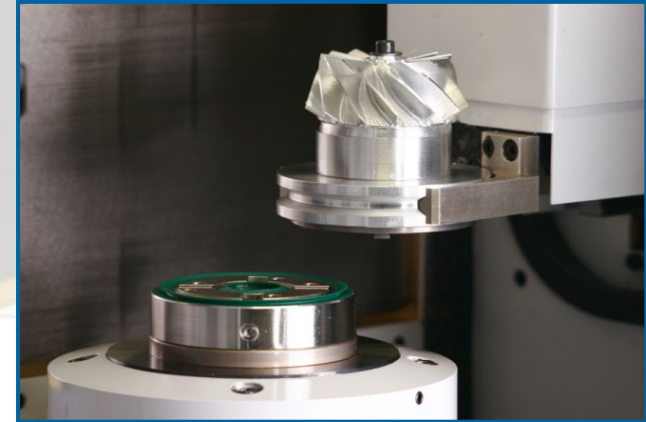
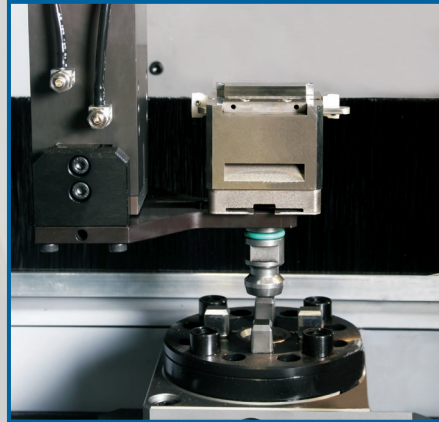

4th-axis rotary, axe A (option)

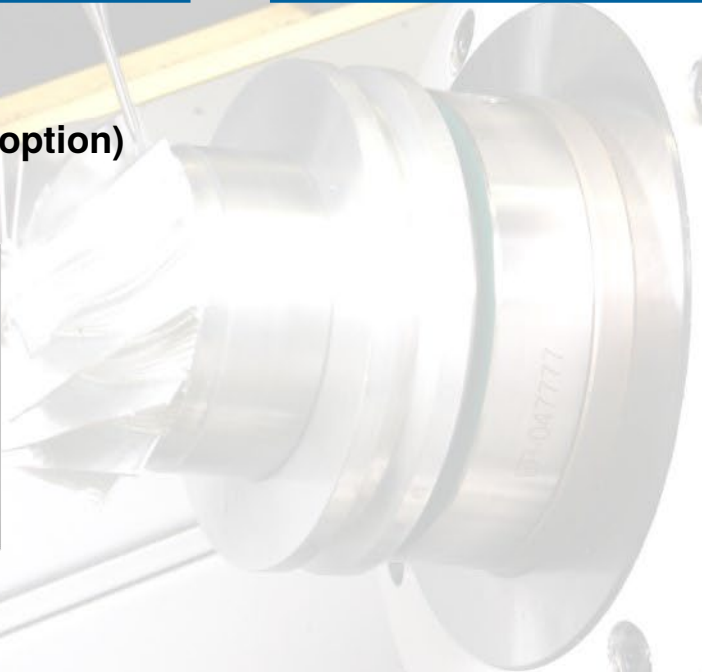
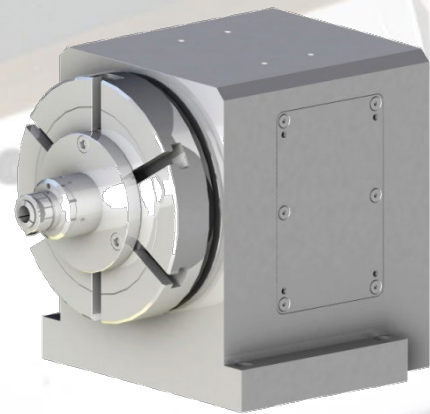

TOOLHOLDER HSK E25

Balanced G2.5 at 50 000 rpm

Beware : For through-spindle coolant, we recommend using specific tips

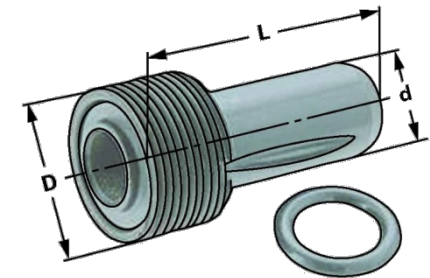
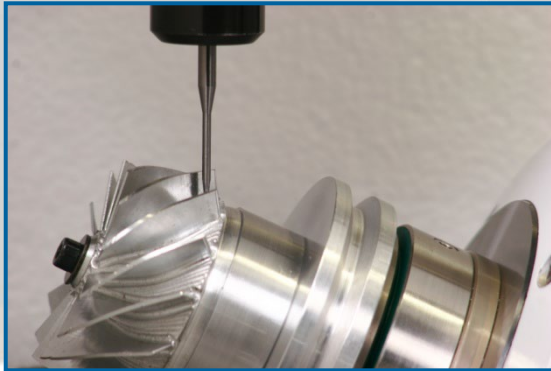

The precision and accuracy of the machine's axis is controlled with laser interferometry

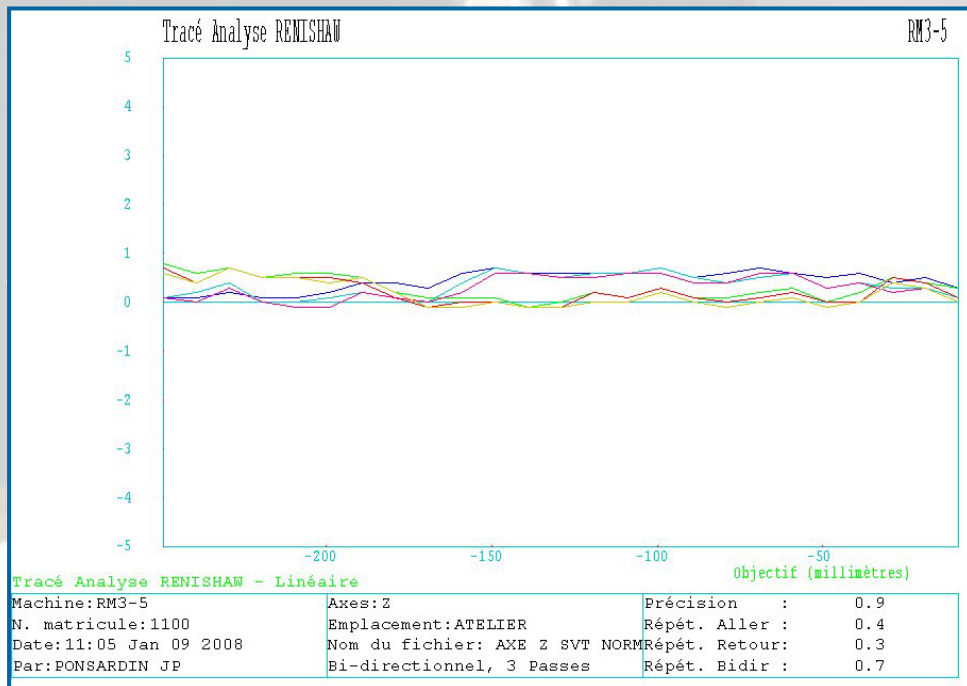

BALLBAR Test

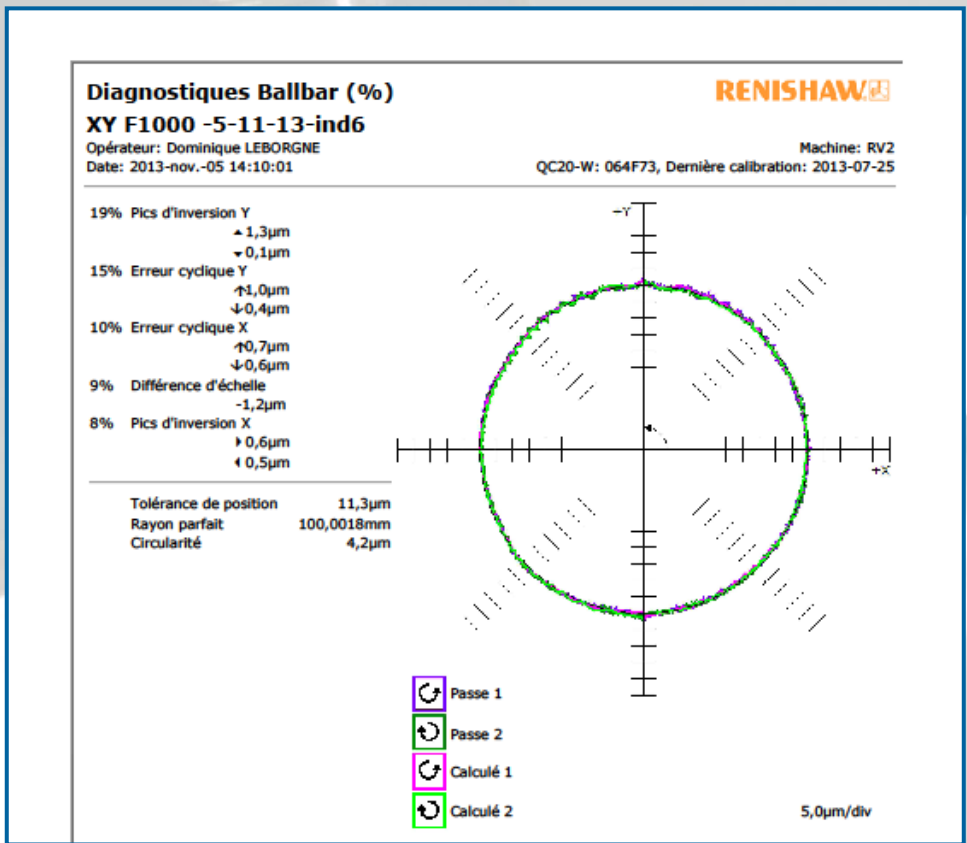

Automatic system for measuring kinematic data

701445 Toolchanger door is open

Kinematic channel1 Name of swivel data record

Name: **RM13_B** Kinematics No.:

Retract:

	X	Y	Z	[mm]
Offset vector I1	0.000000	0.000000	-134.225000	[mm]
Rotary axis vector V1	0.000000	239.225000	0.000000	
Offset vector I2	0.000000	0.000000	134.225000	[mm]
Rotary axis vector V2	0.000000	0.000000	0.000000	
Offset vector I3	0.000000	0.000000	0.000000	[mm]

Swivel mode Axis by axis

Rotary axes direct	<input type="checkbox"/> No	<input type="checkbox"/> Track tool	<input type="checkbox"/> No
Projection angle	<input type="checkbox"/> No	<input type="checkbox"/> B axis kinematics	<input type="checkbox"/> No
Solid angle	<input type="checkbox"/> No		
Direction refer.	<input type="checkbox"/> Rotary axis 1, - direction selected		
Enable	<input checked="" type="checkbox"/> Yes		
JobShop functions	<input type="checkbox"/> Automatic swivel data record change		
	<input type="checkbox"/> Automatic tool change		

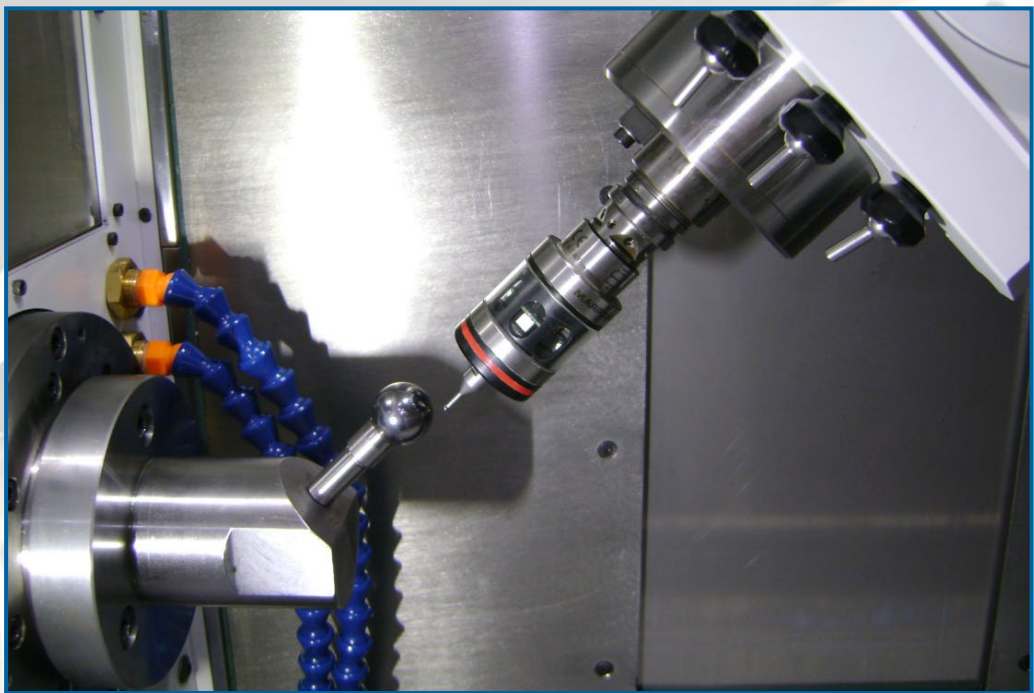

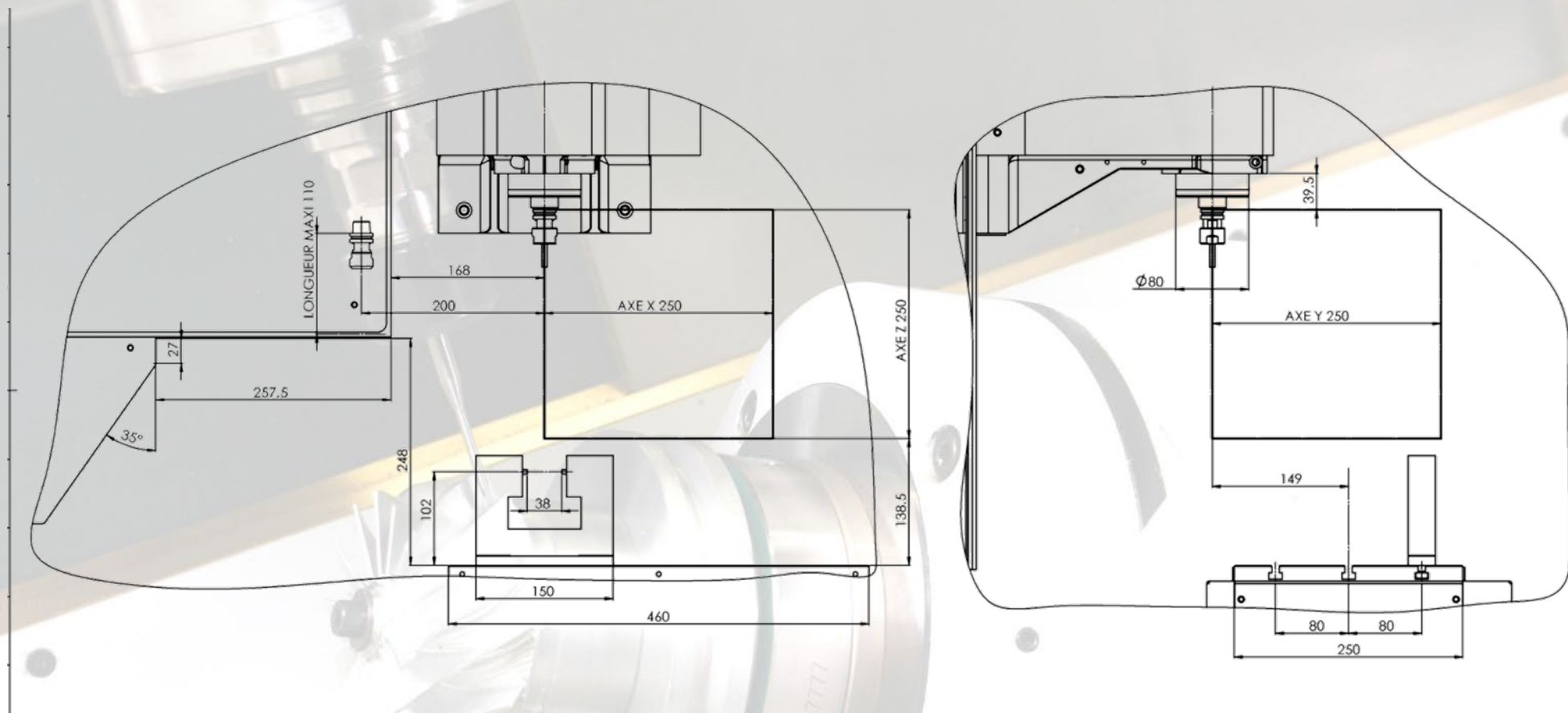

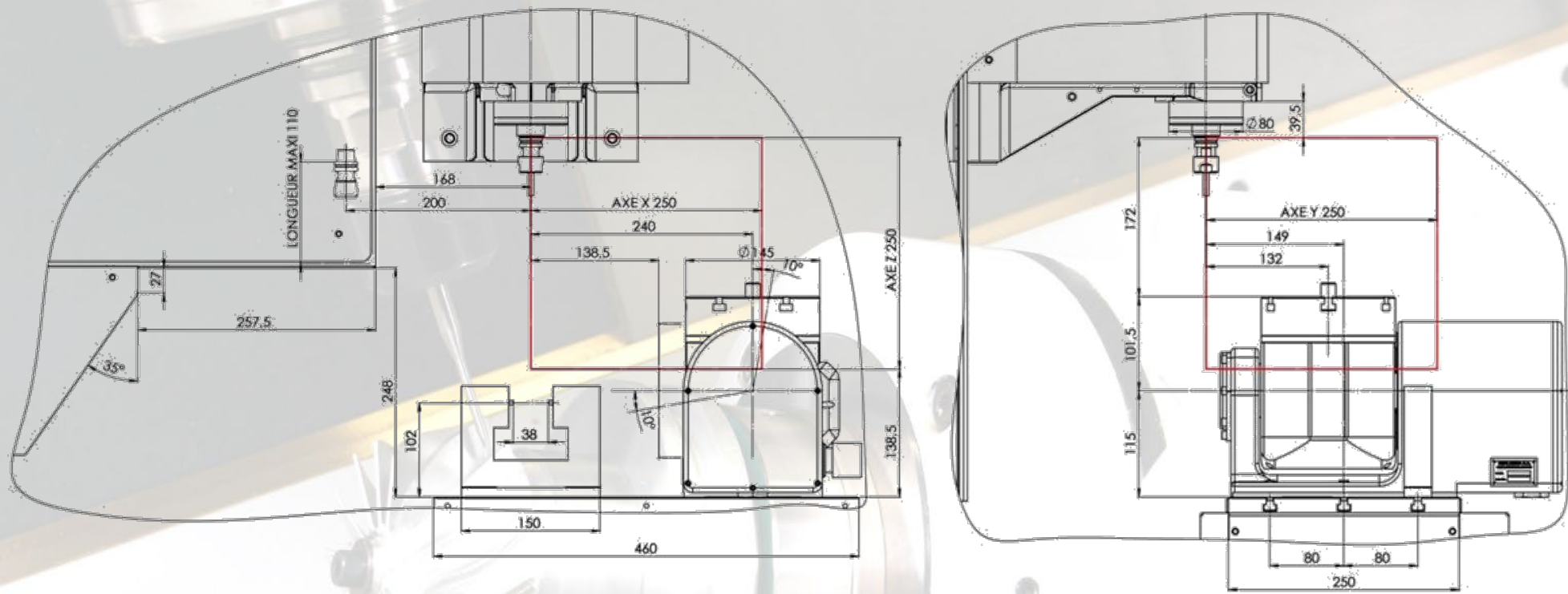

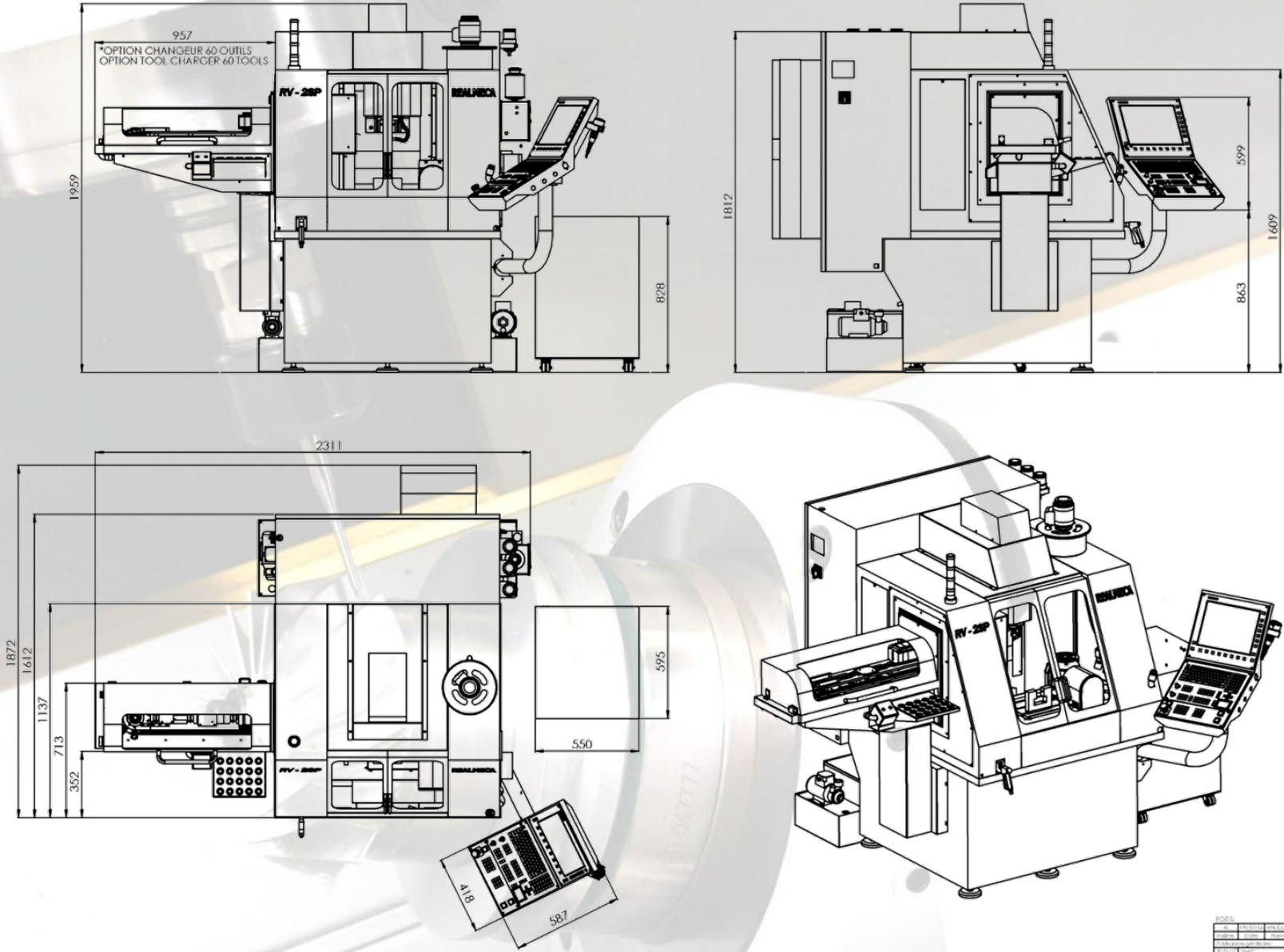

REVISION			
REV.	DESCRIPTION	DATE	BY
01	01	01	01

REALMECA

B.P.10 – 1 route d'Aubréville
55120 Clermont-en-Argonne – FRANCE

Tél. : +33 (0)3 29 87 41 75 – Fax : +33 (0)3 29 87 44 46

commercial@realmeca.com

www.realmeca.com

